

F1 SERIES

# FYNE ADVICE

---

ESSENTIAL INFORMATION GUIDE



FYNE  
AUDIO



# TABLE OF CONTENTS

1. Introduction
2. Technology
3. Positioning
4. Fitting floor coupling spikes
5. Amplifier choice
6. Cable choice
7. Connecting speaker cables
8. Earth connections
9. Adjustments
10. Care of cabinet
11. Warranty
12. Specification

# 1 INTRODUCTION

Thank you for choosing Fyne Audio F1 Series loudspeakers, proudly designed by our experienced team of engineers, and constructed to the highest standards by artisans in our own facility in Scotland. We believe they will give you many years of listening pleasure.

- Before installing these loudspeakers please read this manual in full, both for safety reasons and to ensure you achieve the best performance possible.
- When unpacking, please follow the instructions carefully, to avoid causing possible injury or damage. Please ensure you have the help of an assistant.
- Please retain packing for possible future use.
- Check contents of the accessories box

## **Your accessories box includes**

- Floor coupling spike M16 (x8)
- Spike locking wheel (x8)
- Floor protection cups (x8)
- Spike adjustment tool (x1)
- Bi-wire links (x4)

# 2 TECHNOLOGY

Our experienced team of acoustic and product design engineers have been in the loudspeaker industry for very many years. Since coming together to form Fyne Audio, they have been augmenting their existing skills and developing new technologies to ensure that we can offer best in class performance through technical innovation and advanced manufacturing techniques.

## **ISOFLARE™ POINT SOURCE DRIVER**

Fyne Audio's IsoFlare™ driver is a point source system whereby the bass / midrange driver shares a common centre with the high frequency unit. Providing outstanding stereo imaging even off axis, energy is radiated isotropically with constant directivity following the flare of the driver cone. Sound is produced emanating from a single point.

To fully optimise the driver performance, every aspect of this meticulous design has been considered. Eliminating unwanted vibrations which would be detrimental to the sound quality, our IsoFlare™ point source drivers are built around a custom tooled rigid cast aluminium chassis. A vented rear chamber in the substantial Neodymium HF magnet places low frequency resonance well below the crossover region. Pushing the break up mode well above the level of human hearing, the highly rigid 75mm titanium alloy high frequency diaphragm delivers a smooth and extended response, while a copper shorting ring provides low distortion. The unique geometry of the high frequency unit's waveguide provides a flat frequency response and avoids internal reflections. The HF diaphragm provides

a natural and unstressed performance, terminated by a Mylar surround to optimally terminate energy. Such a large diaphragm allows a very low crossover frequency of 750Hz to the bass / midrange cone, ensuring much of the vocal range is handled by the tweeter.

The HF unit annular waveguide has a computer optimised expansion rate and geometry to provide flat frequency response and avoid internal reflections, while the high power edgewound aluminium HF voice coil on Kapton® former eliminates thermal compression.

On the low frequency section, the twin roll fabric surround effectively terminates cone energy, without time-smearing. A multifibre paper cone gives natural sounding midrange and clean transient behaviour, while the high power LF motor system uses ferrite magnet, with rectangular copper voice coil on an aluminium former, to aid power dissipation. A copper shorting ring on the pole piece reduces eddy currents, reducing midrange distortion tenfold.

## **CROSSOVER**

Although simple in topology, the design is computer optimised, fine tuned subjectively by critical auditioning.

The crossover makes use of high quality precision components, including low loss LF laminated iron core inductors, non-inductive thick film resistors and Claritycap's high grade MR type HF polypropylene capacitors. High quality gold plated WBT Nextgen™ bi-wire terminals are used, together with Neotech™ PC-OCC internal wiring with virtually no crystal imperfections for transparent signal transfer. The components are hard wired on fibre board panels to minimise vibration, using a special mastic.

A specially designed autotransformer using the highest grade silicon steel laminations impedance matches the HF compression driver to the amplifier, with varnish vacuum impregnation to eliminate distortion caused by winding vibration.

Cryogenic treatment of the complete crossover relaxes stresses in materials and solder joints to maximise signal transparency. A grounding terminal is fitted to minimise the effect of radio frequency interference masking fine detail.

## **BASSTRAX™ TRACTRIX DIFFUSER SYSTEM**

The F1 Series employs a downwards firing port arrangement using a twin cavity reflex loading system. This loading system broadens the tuning frequency to reduce cone excursion, and acts as a muffler, blocking standing waves produced by the main internal port.

Below the vent in the base of the loudspeaker, the BassTrax™ Tractrix profile diffuser (patent applied for) is used to convert the plain wave energy to an expanding spherical 360-degree wavefront, dispersing energy uniformly into the room. This Tractrix profile has been previously applied to horn loudspeakers by Voight in the 1920's, but the application to a diffuser of this type is novel and subject of a patent application.

The BassTrax™ Tractrix profile is known to maintain a 90 degree angle at each intersection of the expanding wavefront, thus avoiding reflections. This clever arrangement also makes the loudspeaker less critical of room positioning.

## **ENCLOSURE**

The high density birch ply construction is pressed to ensure an extremely rigid and low colouration structure. The drive unit is coupled to internal bracing panels through damping material to absorb energy.

The high mass machined aluminium platform, provides exceptional stability for precise low frequency performance and resolution of fine detail and also is an integral part of the BassTrax™ diffuser system.

Heavy duty support spikes, adjustable from above enable precise levelling, with the provision of machined aluminium cups for protection on wooden floors.

# 3 POSITIONING

**This operation should be performed by two people to avoid injury or damage to the loudspeaker, should it slip or fall.**

With the loudspeaker still located on the foam end cushions, start by positioning the loudspeakers with their rear at least 0.5m from the rear wall. The proximity of a side wall should be no closer than 1m (Fig. 1). Remember that proximity to the

rear and side wall will influence both the bass performance and stereo imaging. Excessively reflective or dissimilar adjacent walls will be detrimental to the stereo image precision. The imaging focus is influenced by toeing in the cabinets towards the listening position. The BassTrax™ diffuser system however, will serve to make the loudspeaker less sensitive to boundary conditions than with a conventional design.

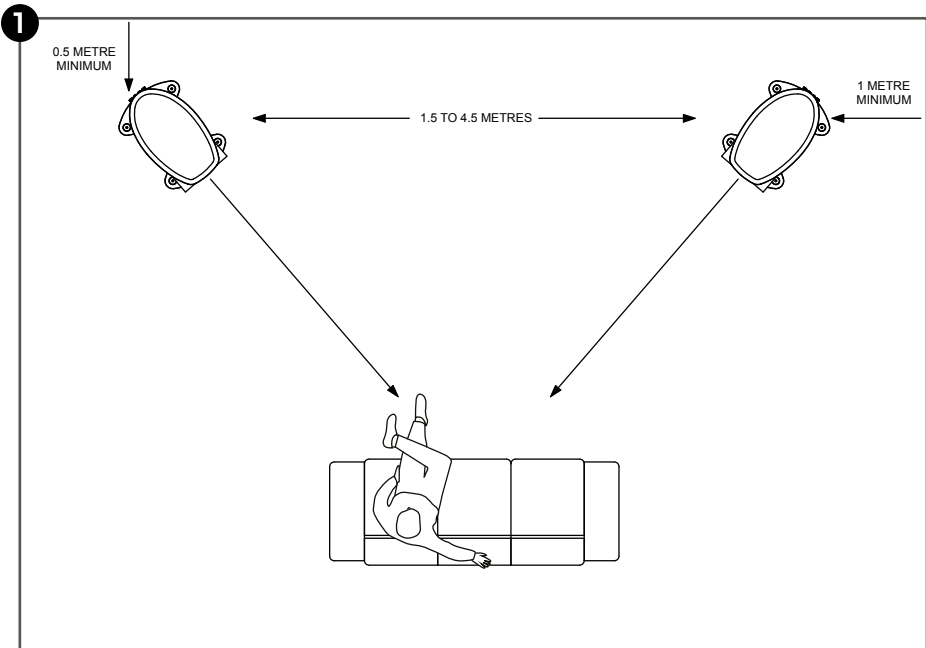

# 4 FITTING FLOOR COUPLING SPIKES

Referring to Fig. 2 - 4 and with the help of an assistant, remove the foam end cushion from one side of the loudspeaker, and fit two of the floor coupling spikes and locking wheels. Repeat for the other side of the loudspeaker.

Using the adjustment tool provided, level the loudspeaker from above and tighten the locking wheels.

Ensure the protective cups are used under the spikes to avoid damage to wooden or other delicate floor surfaces.

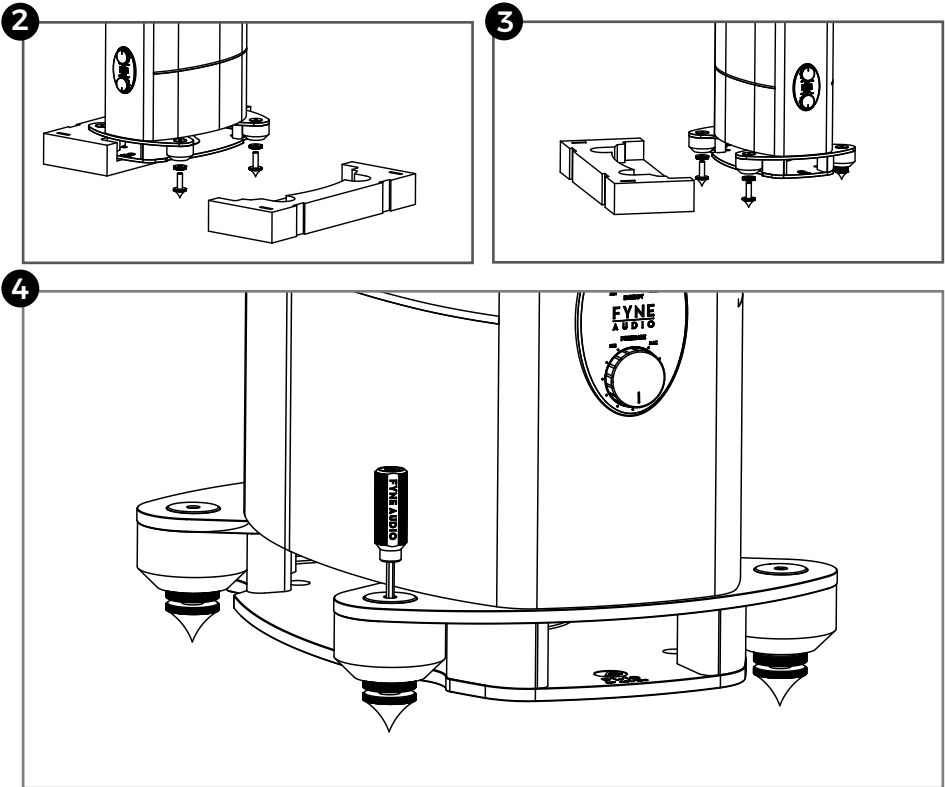



## 5 AMPLIFIER CHOICE

The advisable range of amplifier powers is detailed in the Specification. Responsible use with higher powered amplifiers is possible, due to the robust design of these loudspeakers.

We do not advocate any specific amplifier technology, i.e. transistor versus valve (tube). As with any high resolution loudspeaker system, it is the quality of the amplification that is paramount in extracting maximum performance from your loudspeakers. Some customers may wish to use valve (tube) amplifiers such as single ended triodes, with output powers less than the minimum recommendation. This will not cause damage to the loudspeakers, but will restrict the maximum volume and dynamic range, especially in large rooms.

If you are considering the purchase of a new amplifier, your dealer will be able to give you recommendations that work well.

## 6 CABLE CHOICE

It is important to use cables of appropriate quality for such a high performance loudspeaker. While from a technical perspective, low electrical resistance is necessary to minimise losses and maximise amplifier damping. The physical construction of the cable including conductor type and purity, together with insulation characteristics have considerable influence on the sound quality. The optimum cable is both subjective and system dependent; your dealer will be able to give advice.

Cables should be terminated in high quality connectors, either 4mm banana or spade. We would recommend the use of WBT Nextgen™ connectors.

# 7 CONNECTING SPEAKER CABLES

Ensure the amplifier is switched off before connecting cables, to avoid damage.

Ensure connections are made positive to positive and negative to negative between the loudspeaker and the amplifier.

The loudspeakers are provided with two sets of terminals, one for the HF and one for the LF section. Wiring may be done in either single wire mode or bi-wire mode. The latter will provide optimum performance.

When using a single cable, wire as shown (Fig. 5), fitting the link cables provided. The best sound quality will be achieved when connecting to the HF terminals. For bi-wire operation, ensure the link wires are not fitted, and wire with two sets of cable, or a dedicated bi-wire cable (Fig. 6). This will ensure the best possible sound quality.

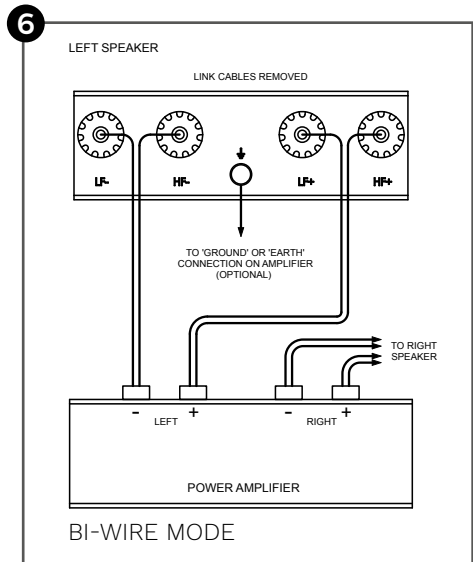
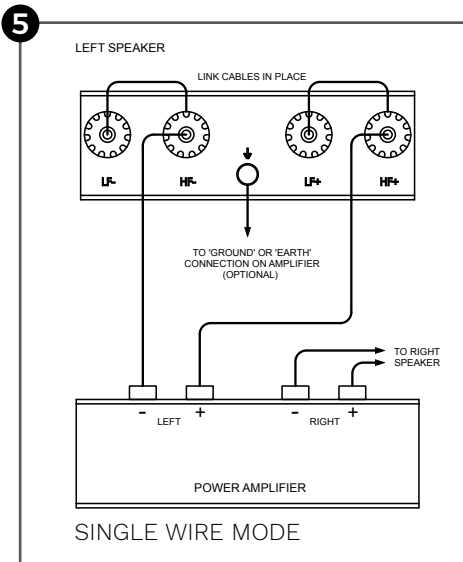

A further option is bi-amping, where the LF and HF sections of the loudspeaker are each driven from their own amplifier, for further enhancement in sound quality. Either two stereo power amplifiers or four monoblock amplifiers may be used. If using

two stereo amplifiers, it is recommended that one is used as the LF channel to both loudspeakers and the other HF (Fig. 7). **To avoid amplifier damage, the link cables must not be in place.**

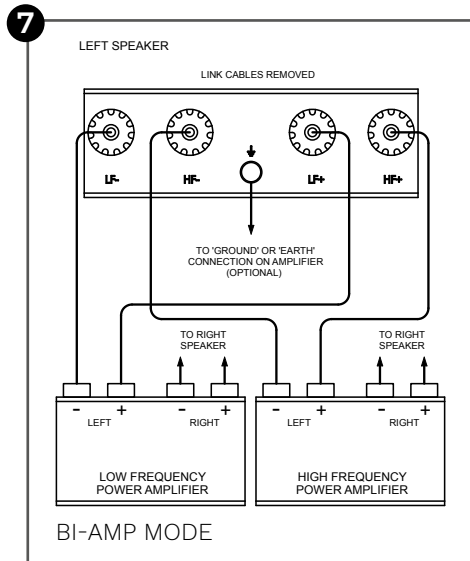

## **8 EARTH CONNECTION**

The loudspeaker is provided with an earth or ground connection, connected to the drive unit chassis. The purpose of this is to ground any radio frequency interference that may get back to the amplifier, reducing fine detail and resolution. A separate earth wire may be used for this purpose, but best results will be obtained by using a dedicated screened loudspeaker cable.

## **9 ADJUSTMENTS**

The F1 Series is provided with two adjustment controls on the front panel, to achieve optimal performance in terms of both the listening environment and listener preference.

The upper 'Energy' control alters the level of signal fed to the tweeter, from the crossover point upwards, giving control over how bright the presentation sounds (Fig. 8).

The lower 'Presence' control only affects the lower treble region of 2.5 - 5.0kHz, and

influences articulation and vocal clarity and having an effect on image depth (Fig. 9).

Start with both controls in the central (level) position, and make small adjustments with well recorded programme material that you are familiar with. Achieving the correct presentation is equivalent to focusing the lens on a camera, to achieve the most realistic sound-staging depth.

## 8 HF ENERGY ADJUSTMENT

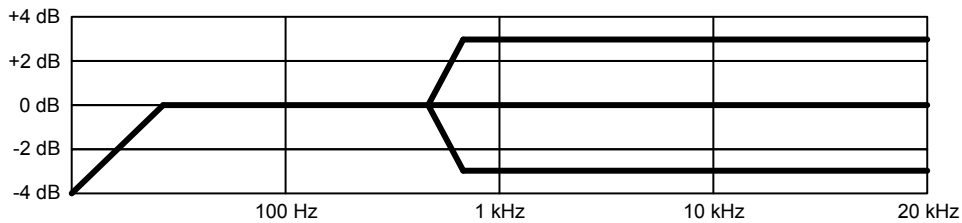

## 9 PRESENSE ADJUSTMENT

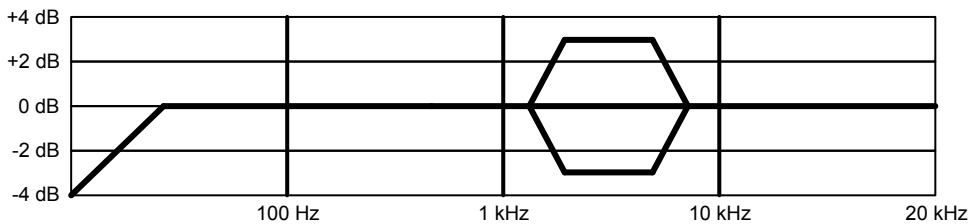

# 10 CARE OF CABINET

The cabinet may be cleaned with a microfiber cloth. Occasionally use a high quality non-silicone furniture polish on the high gloss wooden areas. As wood is a natural material, avoid exposure to extremes of heat, humidity and direct sunlight for extended periods of time.

If unused for long periods of time, you may wish to cover the loudspeakers with the cloth bags they were packaged in, to provide protection.

**On no account use solvents or abrasive materials, as this will cause damage and invalidate the warranty.**

# 11 WARRANTY

No maintenance of the loudspeaker is necessary.

Please register your Fyne Audio Limited product online at [www.fyneaudio.com](http://www.fyneaudio.com). All of our products have been produced and tested with care and precision to give first-class service.

The F1 Series loudspeakers is guaranteed for a period of 7 years from the date of purchase from an authorised Fyne Audio Limited dealer. This warranty is subject to the absence or evidence of misuse, overload, or accidental damage, applies only to the registered owner, and covers only genuine Fyne Audio Limited products with the original undamaged serial number. If at any time during this warranty period the equipment proves to be defective for any reason other than accident, misuse, neglect, unauthorised modification, incorrect installation or connection, matched with improper equipment or fair wear and tear, we will repair any such manufacturing defect or, at our option, replace it without charge for labour, parts or return carriage.

If you suspect a problem with a Fyne Audio Limited product, in the first instance, discuss it with your Fyne Audio Limited dealer. If you require further assistance then we ask that you deal directly with your local Fyne Audio Limited distributor. If you cannot locate your distributor please contact Fyne Audio Limited Customer Services, via our website listed above or at the e-mail [enquiries@fyneaudio.com](mailto:enquiries@fyneaudio.com)

Do not ship any product to Fyne Audio Limited without previous authorisation.

## **LIABILITY**

Other than the warranty and services set out in this warranty, to the fullest extent permitted by law, Fyne Audio Limited and its Authorised Distributors shall not be liable to you and / or any third party or entity whatsoever for:- any loss, damages and /or malfunction caused to any product(s) which is / are connected to any of the Fyne Audio Limited products. Any damages, loss and liability (except for any personal injuries or death), whether direct, indirect, incidental, consequential special, punitive or otherwise, howsoever caused by, arising out of, or otherwise in relation to the installation, delivery, use, service, repair, replacement and / or maintenance of the Fyne Audio Limited product; or any damages, loss and liability (except for any personal injuries or death) under this warranty in respect of any act, omission, or negligence of any of their technicians, employees, agents, representatives or independent contractors relating to the actual or purported performance of any of the obligations under this warranty.

Without limiting the above, the maximum liability of the Fyne Audio Limited and its Authorised Distributors under this warranty shall not in any event or under any circumstances exceed the actual purchase price paid for the Fyne Audio Limited product(s).

# 12 SPECIFICATIONS

	<b>F1-10</b>
<b>System type</b>	2 way, downwards firing port, with BassTrax™ Tractrix diffuser*
<b>Recommended amplifier power</b> (Watt RMS)	20 - 280
<b>Peak power handling</b> (Watt peak)	500
<b>Continuous power handling</b> (Watt RMS)	140
<b>Sensitivity</b> (2.83 Volt @ 1m)	94dB
<b>Nominal impedance</b>	8 Ohm
<b>Frequency response</b> (-6dB typical in room)	28Hz- 26kHz
<b>Drive unit complement</b>	1 x 250mm IsoFlare™ point source driver, multi-fibre bass / midrange cone, with 75mm titanium alloy dome compression tweeter, neodymium magnet system
<b>Crossover frequency</b>	750Hz
<b>Crossover type</b>	Bi-wired passive low loss, 2nd order low pass, 2nd order high pass, Deep Cryogenically Treated
<b>System adjustments</b>	High frequency energy (750Hz - 26kHz) +/- 3dB Presence (2.5kHz - 5.0kHz) +/- 3dB
<b>Dimensions</b> - HxWxD	1191 x 405 x 581mm (46.9 x 15.9 x 22.9")
<b>Cabinet construction</b>	Birch ply with solid wood trim and extensive internal bracing
<b>Weight</b> - Inc Spikes	57.7kg (127.2lbs)

\* Patent applied for



**F1-12**

<b>System type</b>	2 way, downwards firing port, with BassTrax™ Tractrix diffuser*
<b>Recommended amplifier power</b> (Watt RMS)	20 - 350
<b>Peak power handling</b> (Watt peak)	600
<b>Continuous power handling</b> (Watt RMS)	175
<b>Sensitivity</b> (2.83 Volt @ 1m)	96dB
<b>Nominal impedance</b>	8 Ohm
<b>Frequency response</b> (-6dB typical in room)	26Hz- 26kHz
<b>Drive unit complement</b>	1 x 300mm IsoFlare™ point source driver, multi-fibre bass / midrange cone, with 75mm titanium alloy dome compression tweeter, neodymium magnet system
<b>Crossover frequency</b>	750Hz
<b>Crossover type</b>	Bi-wired passive low loss, 2nd order low pass, 2nd order high pass, Deep Cryogenically Treated
<b>System adjustments</b>	High frequency energy (750Hz - 26kHz) +/- 3dB Presence (2.5kHz - 5.0kHz) +/- 3dB
<b>Dimensions</b> - HxWxD	1350 x 450 x 680mm (53.2 x 17.7 x 28.6")
<b>Cabinet construction</b>	Birch ply with solid wood trim and extensive internal bracing
<b>Weight</b> - Inc Spikes	72.0kg (158.7lbs)

\* Patent applied for

**ENJOY.**



Thank you for choosing Fyne Audio loudspeakers, proudly designed by our experienced team of engineers in Scotland, and constructed to the highest standards.

---

**WWW.FYNEAUDIO.COM**

F6480 0001

 FYNEAUDIO

 @FyneAudio

7 February 2019