

*Mofi*

ELECTRONICS

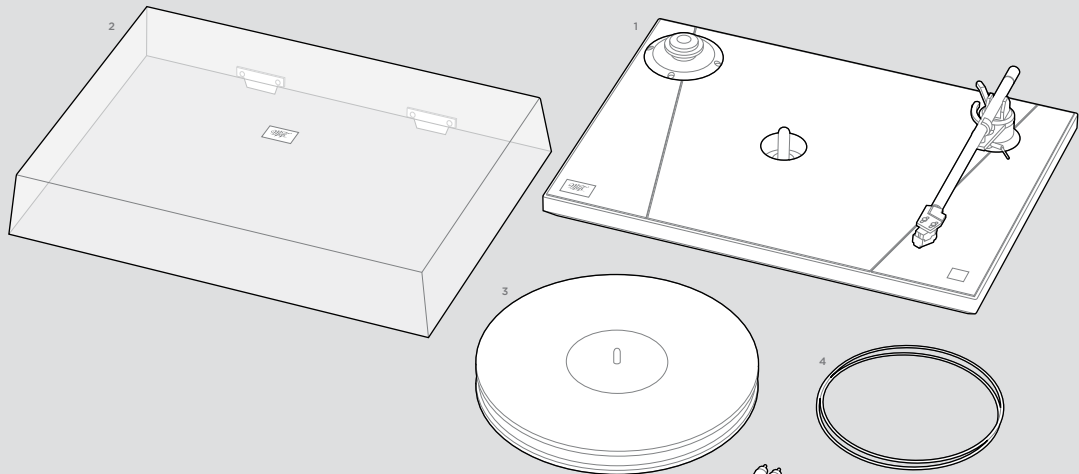

## IN THE BOX

1. UltraDeck™ Turntable
2. Dustcover
3. Delrin® Platter
4. Platter Belt
5. RCA Interconnects
6. Power Cord
7. Counterweight
8. Additional Parts
  - Hex Wrench (2)
  - Anti-skate Weight
  - Stylus Brush

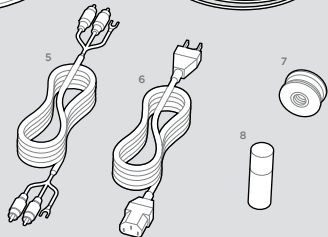

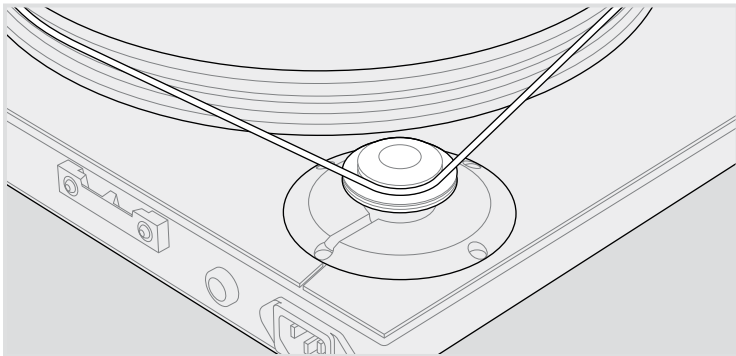
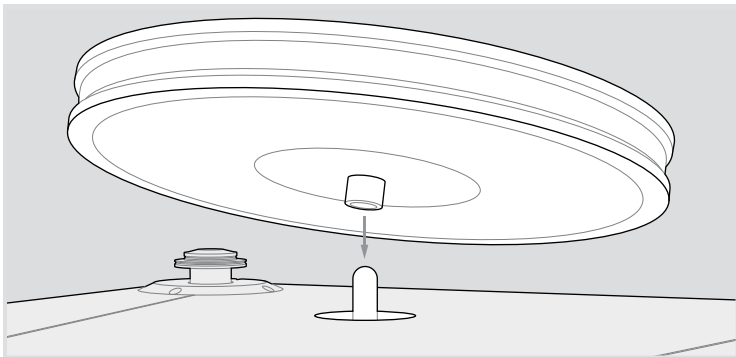

## ASSEMBLY

- ❶ Make sure UltraDeck™ is placed on a level surface
- ❷ If cartridge is not included, follow cartridge manufacturer's installation instructions

Carefully place the Delrin® platter on the bearing hub, making sure it spins freely.

Install the turntable belt, with the belt attached to the top pulley for 33 RPM records, and the bottom pulley for 45 RPM records.

## TRACKING FORCE AND ANTI-SKATE

Install the supplied counterweight onto the tonearm's endstub and balance the arm for zero-tracking. Using a stylus force gauge, rotate the counterweight until the desired tracking force is achieved per your cartridge manufacturer's specifications.

Attach the anti-skate weight with loop to the anti-skate pin, and dress the remaining line and weight to the arm's anti-skate hanger. Set the loop to the suggested notch on the pin based on your cartridge's weight. Each notch reads from front to back:

**Notch 1:** 4g - 6g cartridges

**Notch 2:** 6g - 8g cartridges

**Notch 3:** 8g - 10g cartridges

**Notch 4:** 10g - 12g cartridges

If UltraDeck™ came with the UltraTracker™ cartridge preinstalled, use Notch 3.

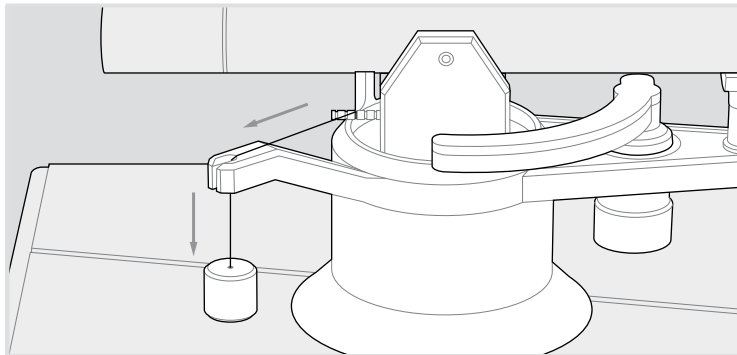
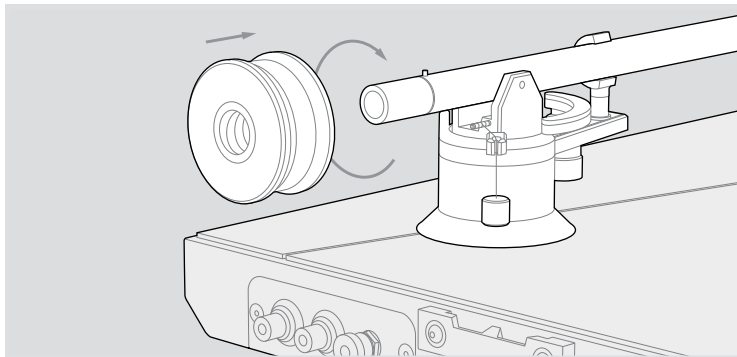

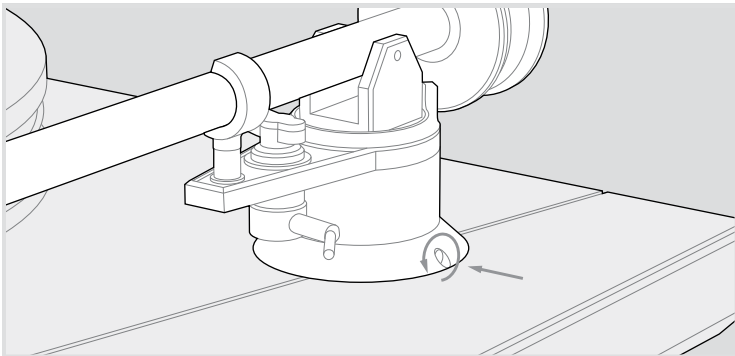

## VTA AND AZIMUTH

**!** If UltraDeck™ came with UltraTracker™ preinstalled, the following steps were completed at the factory

After setting tracking force and anti-skate, adjust the tonearm's height. Loosen the hex screw located at the base of the tonearm to raise or lower the arm height, and tighten once the arm is parallel to the record surface.

Next, adjust your headshell and cartridge for correct azimuth. Loosen the hex screw located under the armtube, then adjust the headshell as needed until it is parallel to the record surface.

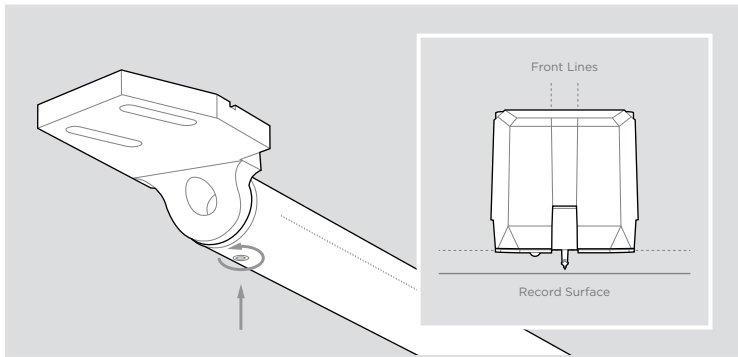

## CONNECTIONS AND LEVELING

Install the RCA interconnects and ground wire to your preamp's phono section, and then connect the power cord from the turntable to any outlet or power conditioner of your choice.

If the turntable is on an unlevelled surface, place a bubble level on the platter, then carefully adjust each foot until the turntable's platter is true.

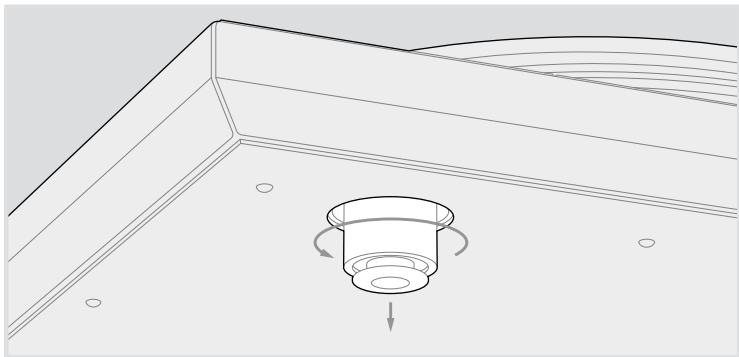
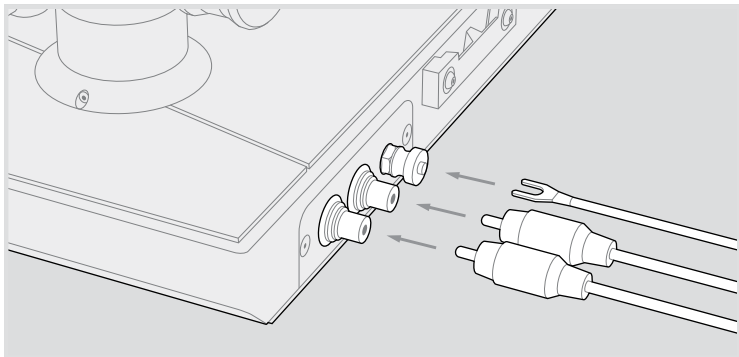

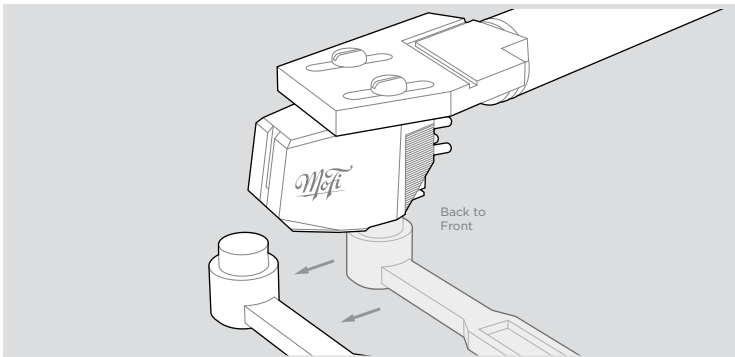

## STYLUS CARE AND DUSTCOVER

- 1 Keep your records clean by using a high-quality record brush and record cleaner

After each play, gently clean your stylus, always brushing back-to-front using the supplied stylus brush. We also recommend using a liquid stylus cleaner such as Mobile Fidelity LP#9.

When not in use, please cover your turntable with the supplied dustcover. For best sonic results, remove the dustcover while playing.

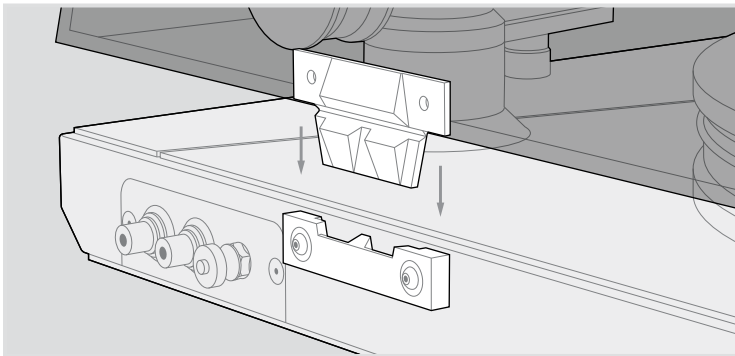

	<b>StudioDeck™</b>	<b>UltraDeck™</b>
Motor	300 RPM AC Synchronous	300 RPM AC Synchronous
Speeds	33 1/3 RPM, 45.0 RPM	33 1/3 RPM, 45.0 RPM
Platter	3.88 lb Delrin®	6.8 lb Delrin®
Wow & Flutter	0.017% - 0.025%	0.017% - 0.025%
Signal-To-Noise Ratio	72dB	74dB
Power Supply Requirements	120V 60Hz, 220-230V 50Hz, 100V 50Hz	120V 60Hz, 220-230V 50Hz, 100V 50Hz
Power Consumption	< 5W	< 5W
Dimensions	19.69" x 5.375" x 14.25"	19.69" x 6" x 14.25"
Weight	19.1 lb	23.1 lb
<b>Tonearm</b>		
Type	10" Straight Aluminum, Gimbaled Bearing	10" Straight Aluminum, Gimbaled Bearing
Overhang	0.75"	0.75"
Offset Angle	22.8° (+/- 2° adjustable)	22.8° (+/- 2° adjustable)
Effective Mass	35g (+/- 0.5g)	35g (+/- 0.5g)
Cartridge Weight Range	5g - 10g	5g - 10g



*MoFi* ELECTRONICS

[www.mofielectronics.com](http://www.mofielectronics.com)

MoFi Electronics - 1811 W Bryn Mawr Ave Chicago IL